

# Honouring every drop

The latest generation of wobble plate pumps

for gentle pumping of highly viscous liquids



safety is our concern

## Protect the quality of your processes and products

From paints and sealants to greases: Pumping highly viscous liquids harbours risks for quality and integrity. The solution: the latest generation of our wobble plate pumps.

The wobble plate pumps have been developed to transport viscous and solid-containing fluids gently and with low pulsation - without causing shear forces and crushing.

With a flow rate of up to 30,000 l/h and a differential pressure of up to 15 bar, the pumps can handle liquids with a viscosity of up to 1,000,000 mPas. The result? Perfect quality and integrity of your processes and products.

But the new wobble plate pumps are not only powerful, robustly manufactured in stainless steel and gentle on the product. They are just as easy to integrate into existing systems as they are fail-safe, easy to clean and low maintenance. This is confirmed by customers from sectors such as the paint and coatings industry, the sealants and adhesives industry, the pharmaceutical industry, the cosmetics industry, the oil industry and the food industry.



### Industrial companies worldwide benefit from:

- Gentle and low-pulsation pumping up to 30,000 l/h
- Precise dosing for optimum process control
- Maximum system availability for uninterrupted production
- Simple cleaning and sterilisation (CIP & SIP)
- Quick maintenance and servicing without disassembly to minimise downtime
- Seamless integration into existing process workflows for efficient processing
- Space-saving design for flexible installation options
- Low energy consumption for cost-efficient operation
- FDA conformity & ATEX certification for the highest safety standards
- Optional temperature control or cooling for precise process control
- Selectable pumping direction depending on requirements





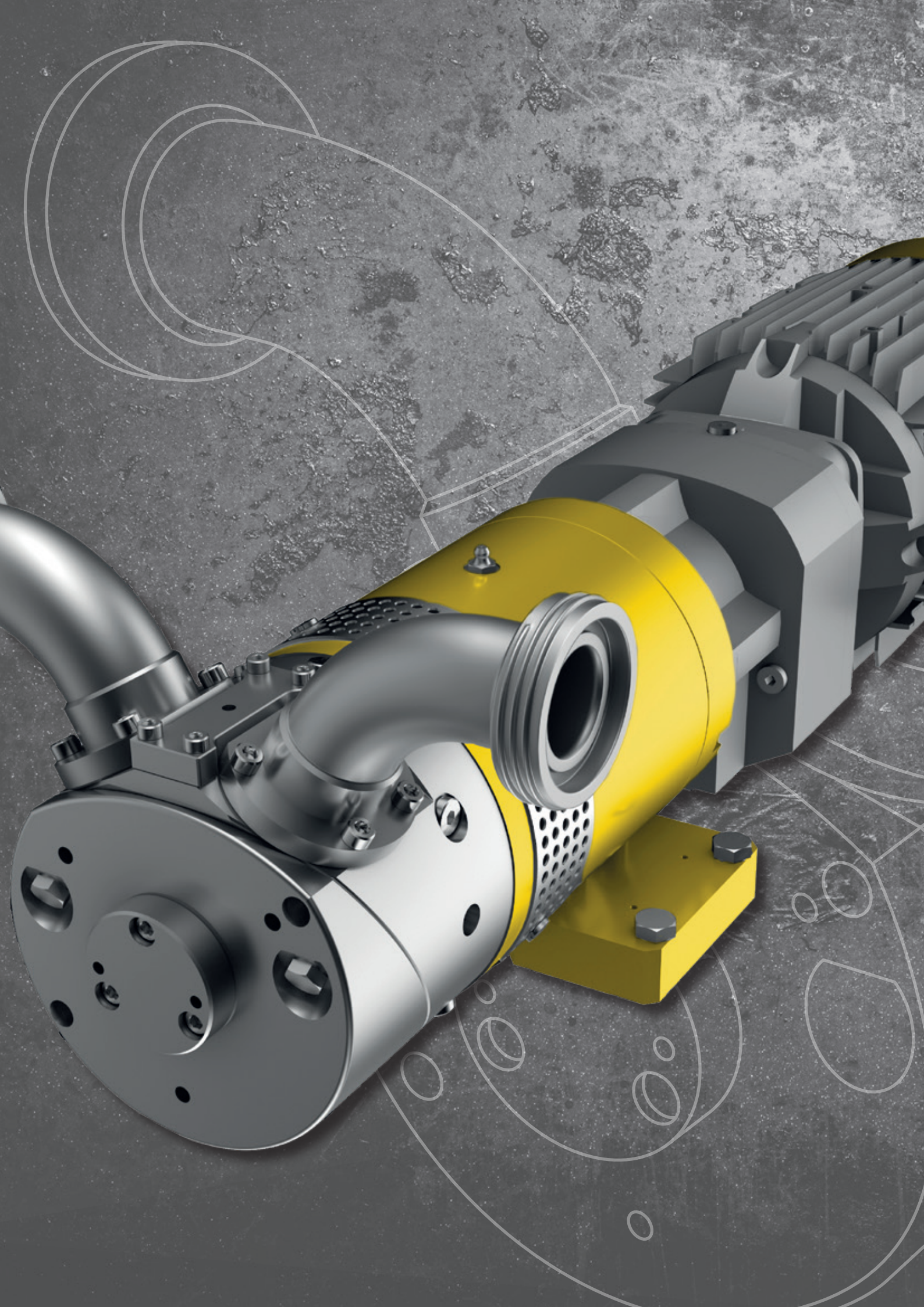



## Anything but complicated

### Wobble plate pumps can be easily integrated into your process workflow

Promised and kept: Our pumps can be installed in no time at all and are quickly ready for use, without high installation costs and without any long interruptions.

You enjoy pure flexibility during installation: Install our latest generation of wobble plate ring pumps horizontally or vertically. The pump head can be rotated in simple 90 degree increments to ensure smooth adaption to existing pipelines.

Our range offers a variety of mounting systems such as flange, milk pipe, TriClamp and Camloc to meet your individual requirements. Alternatively, a mobile assembly on a trolley is available.

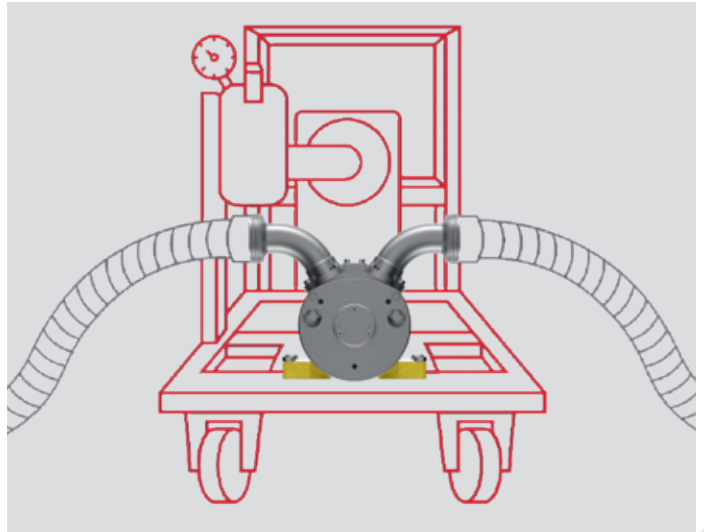

Mobile application

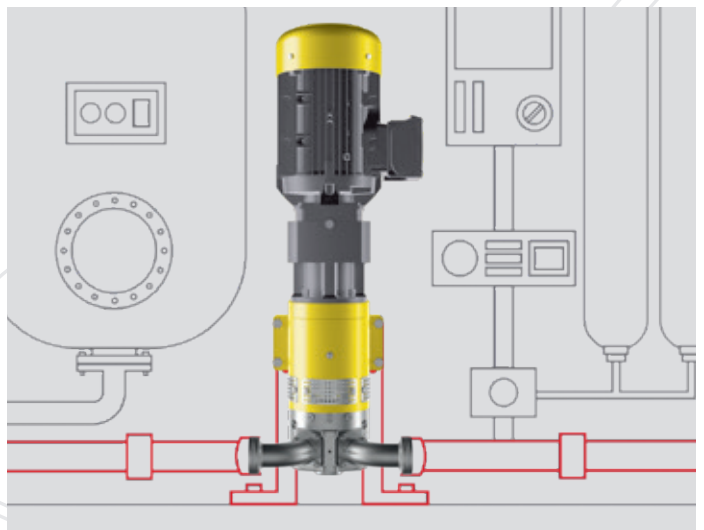

Vertical application

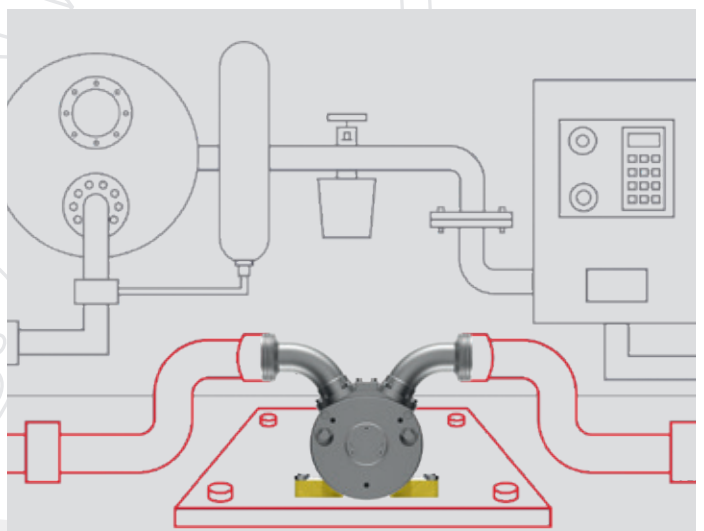

Horizontal application

Rotatability of the pump head for optimal adjustment to the plant in 90° steps

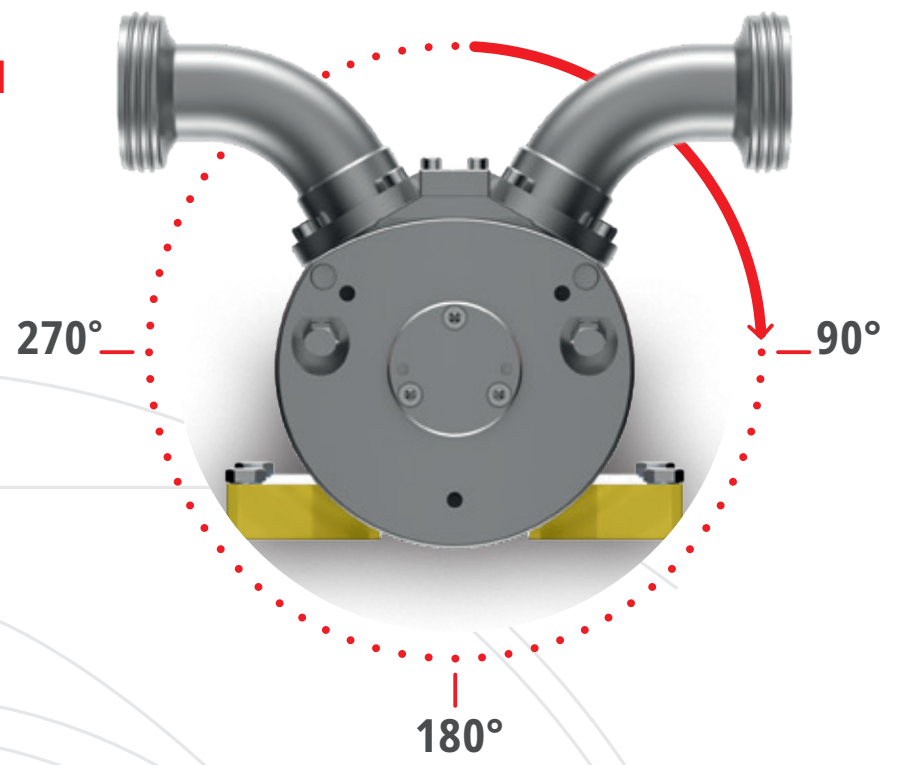

Connection types:

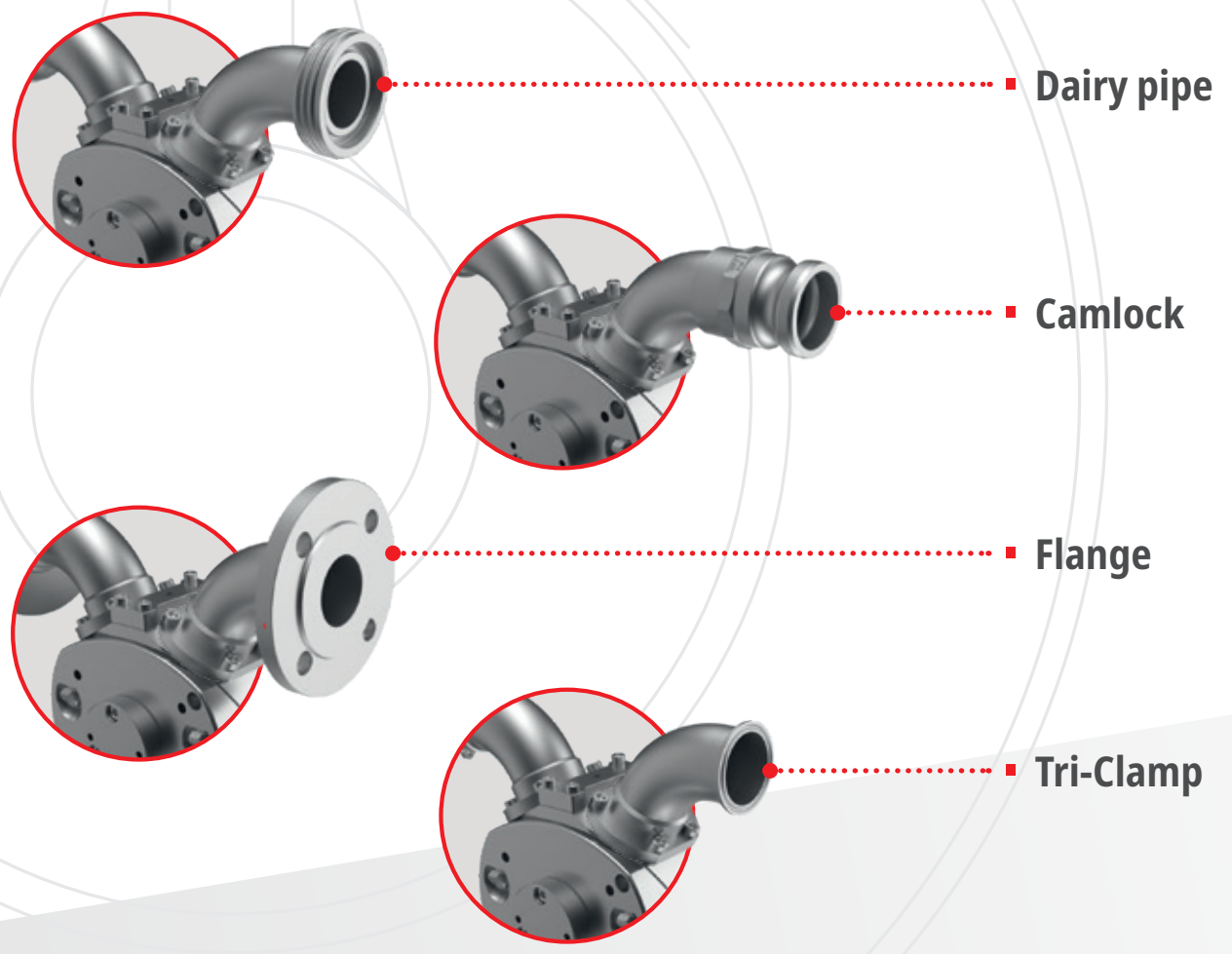

## A choice without agony

### Pump models for every requirement – can be customised on request

In our product portfolio, you will find three standard models of the wobble plate pump, which are already pre-assembled and ready for use in stock. They cover the most common pump applications in the industry.

You also have the option of customising a pump for special requirements. Our customised solutions enable you to optimally adapt the swash ring pumps to your production processes and maximise the efficiency of your systems.

## The power of the tumbling plate

### How the wobble plate pump works briefly explained

Our latest generation of wobble plate pumps utilise a proven principle. A spherical housing contains a wobble ring that is positioned at an angle on a shaft. The rotation of the shaft causes the plate to perform a characteristic wobbling movement. It continuously changes the volume of two chambers on both sides of the shaft. This creates alternating positive and negative pressure, which draws liquids into the pump and expels them through an outlet opening.

An efficient and product-friendly principle that has proven its worth with highly viscous liquids such as oils, greases, paints, sealants and silicones.

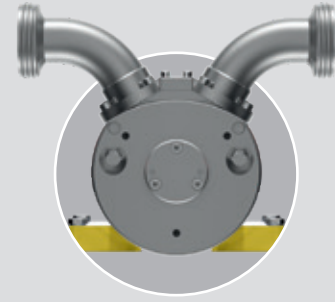

### The entry-level version: Model TRP015

The TRP 015 offers you an entrance into the world of wobble plate pumps. With a flow rate of 6,000 l/h, it is suitable for small to medium-sized applications.

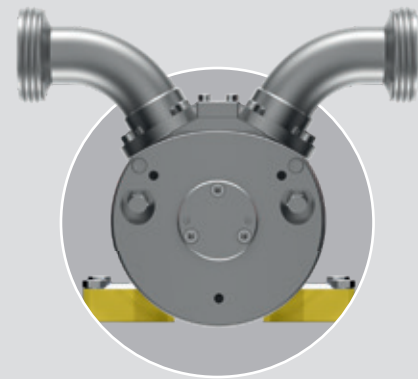

### The middle class: TRP030

The TRP030 is the right choice for medium to large applications. The flow rate of this mid-range pump is 12,000 l/h.

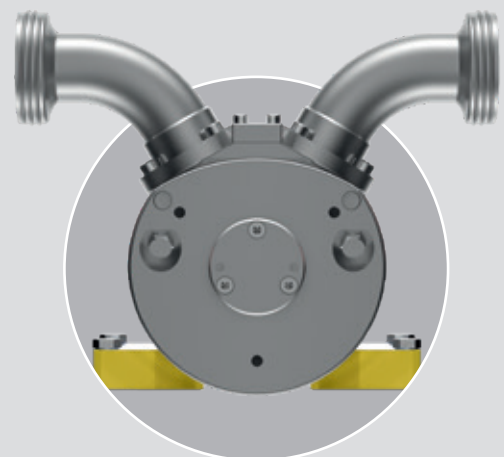

### The Goliath: TRP080

The TRP080 is the Goliath of our latest generation of wobble plate pumps. With a flow rate of up to 30,000 l/h, the pump is suitable for large industrial applications.

**Technical data**

	Model TRP015	Model TRP030	Model TRP080
Pump pressure:	up to 10 bar	up to 15 bar	up to 15 bar
Pump capacity:*	up to 6,000 l/h	up to 12,000 l/h	up to 30,000 l/h
Rated motor power:	3 kW	5.5 kW	7.5 kW
Dimensions:	Diameter: 150 mm Length: 316 mm (plus motor and gearing)	Diameter: 170 mm Length: 340 mm (plus motor and gearing)	Diameter: 210 mm Length: 440 mm (plus motor and gearing)
Weight:	45 kg (plus drive)	90 kg (plus drive)	135 kg (plus drive)
Pump head material:	Stainless steel	Stainless steel	Stainless steel
Wobble plate material:	Plastic or metal (depending on medium)	Plastic or metal (depending on medium)	Plastic or metal (depending on medium)

\*Viscosity 1 - 5 mPas

**Characteristic curve**

with water (18°C) as medium

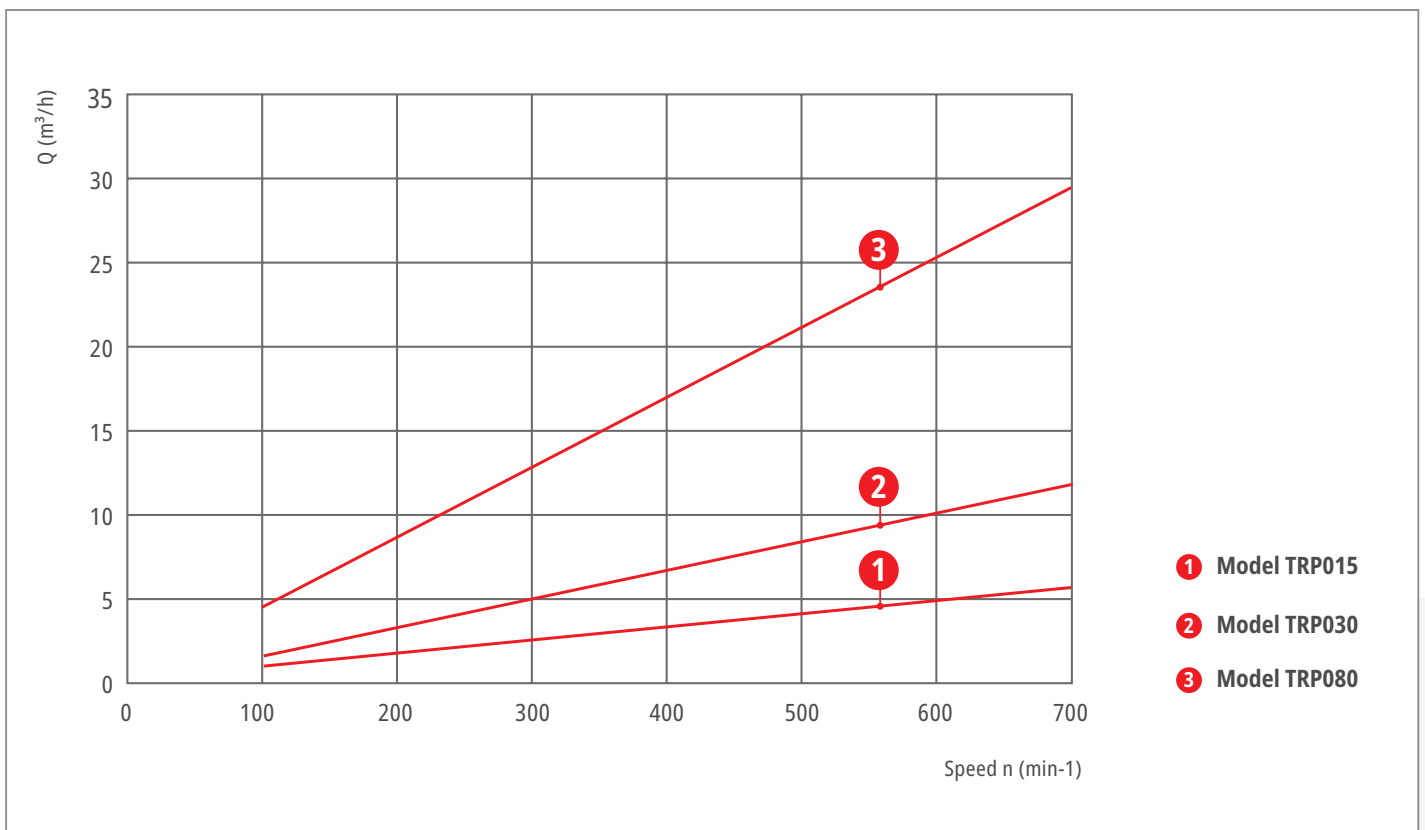

The performance values are theoretical. They are based on Newtonian viscosities of approx. 1.00 mPas. The rated motor power is individually adjusted, depending on the application. Water may be pumped only when using a suitable configuration or only when authorised by the manufacturer.

## What users of the new wobble plate pumps say

**“Shorter cleaning time”, “The desired consistency is retained”,  
“A more appealing product in total”**

”

*“Now that we have put the new pumps into operation, we realise that the desired air bubbles in the shampoo are hardly damaged during the pumping process and we can offer the customer a more appealing product in total.”*

**Plant technician at a cosmetics company**

”

*“Since we have been using the pumps, we have noticed significantly less shear when pumping our liquid. This maintains the desired consistency”*

**Plant technician at a pharmaceutical company**

”

*“Our cleaning time has been significantly reduced by using the wobble plate pumps. This means we can change between different colour shades of dispersion paints more quickly and, above all, we no longer have any contamination from the previously pumped paint”*

**Plant technician at a paint and coatings company**





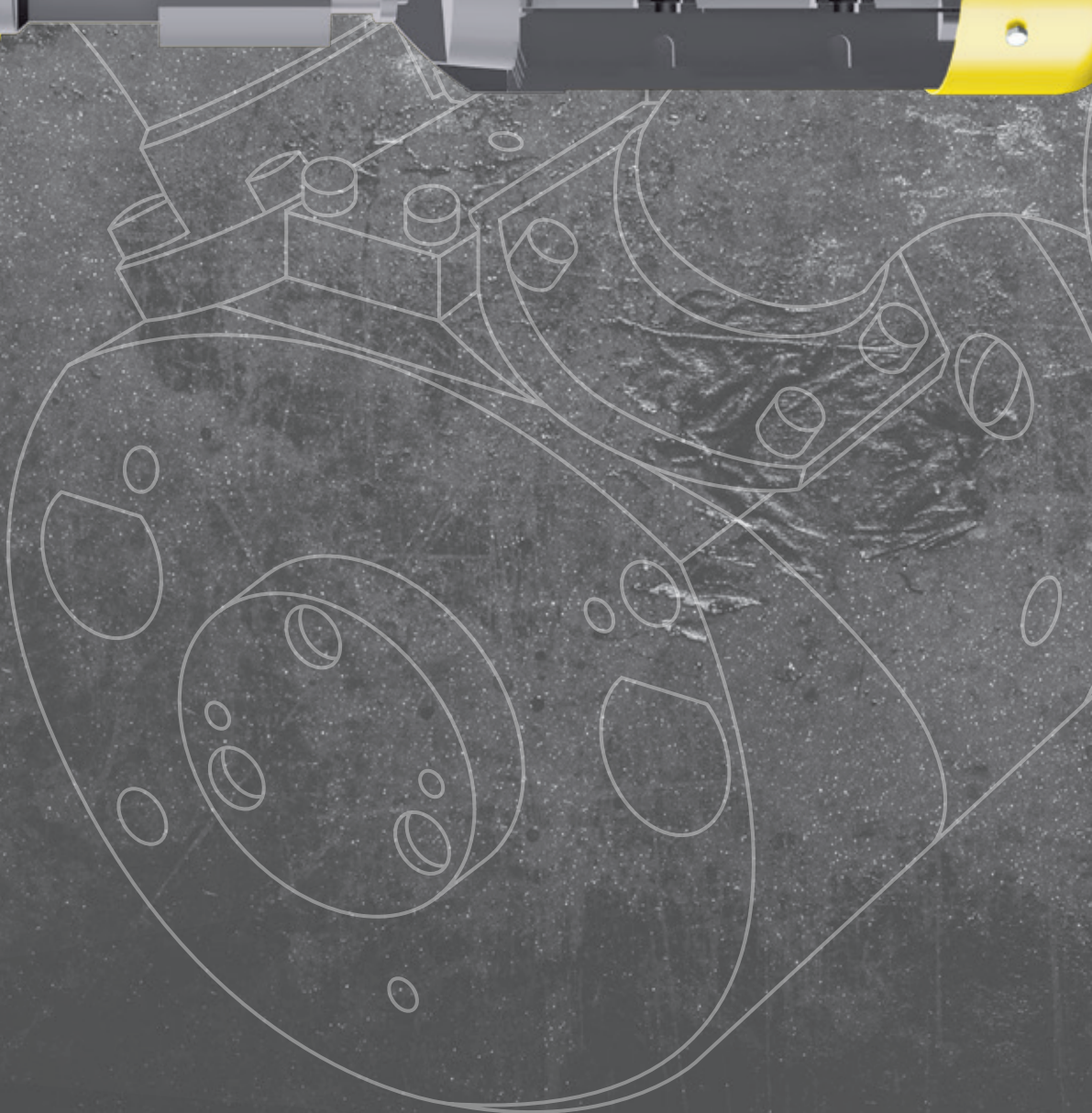
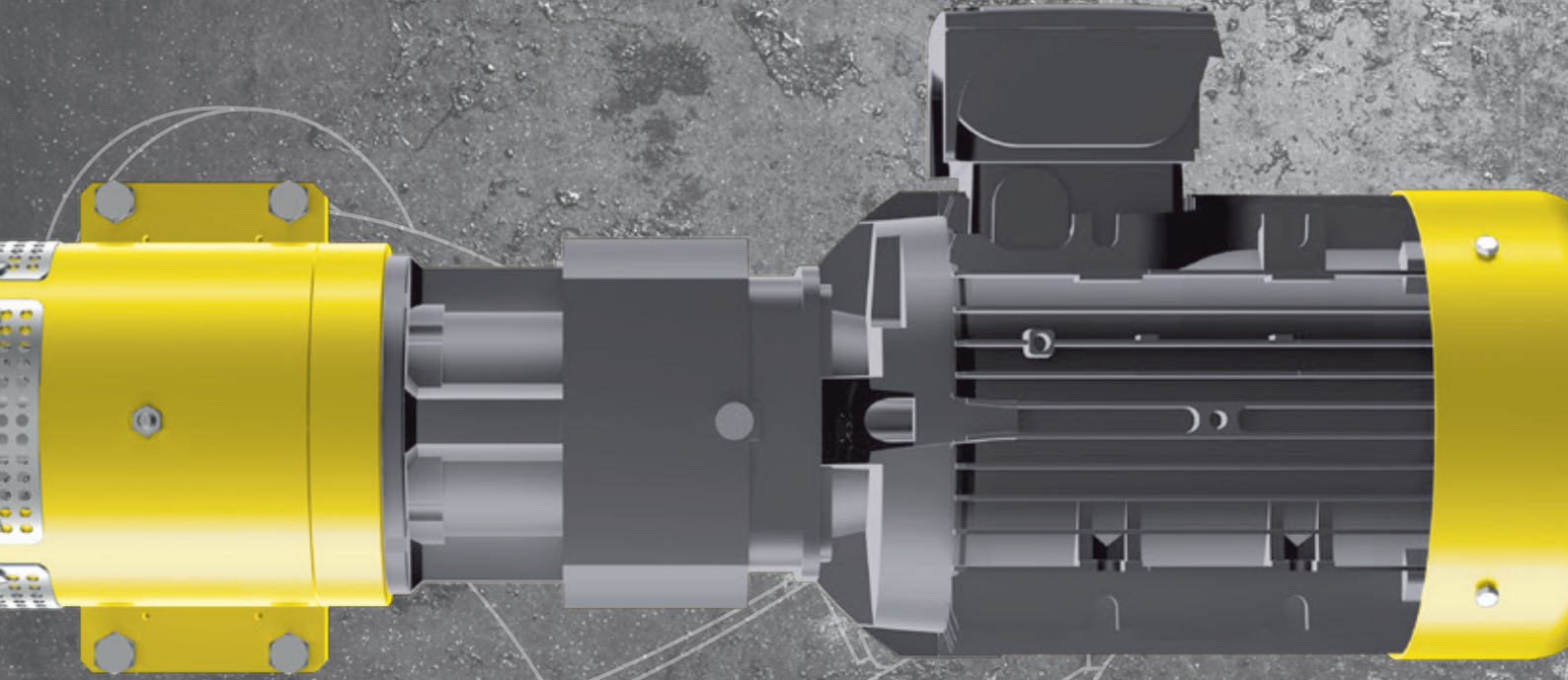



# Take advantage of our accessories programme



## For efficient utilisation of your wobble plate pump

A well thought-out range of accessories is essential for the smooth and safe use of your wobble plate pump. Regardless of whether you work on a mobile basis or have your pumps permanently integrated into a system: with accessories from Lutz, your pump becomes a complete pumping system.



### Discharge spout

for direct filling and transferring into containers

.....



### Nozzles

for safe transferring of liquids

.....



### Lifting device

for safe lifting/lowering of the pump

.....



### Connections

Tri Clamp, milk pipe thread, aseptic, wine screw connection

.....

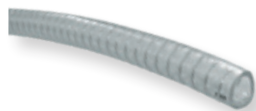

### Hoses

available in many materials/designs

.....



### Hose connections and hose connectors

suitable for all applications

.....

You will find further accessories on our website:  
[www.lutz-pumpen.de/en/accessories](http://www.lutz-pumpen.de/en/accessories)



## With our service, you are guaranteed not to get into a wobble



### We are at your side - from purchase advice to integration and operation

You are not just looking for a pump, but a solution. It is our aim to provide you with a smooth experience - from the first consultation through to long-term, trouble-free operation. To achieve this, we rely on a global network of experienced representatives who are always on hand to provide you with help and advice.

Rely on us to maximise your productivity and reduce downtime to a minimum. With Lutz pumps you are always one step ahead.



Online guide



Download Centre



Spare parts



Repair videos

Do you have any questions about our products, do you need assistance with the selection for your project or are you looking for a contact person on site?

**Our experts will be happy to advise you:**

**[anfrage@lutz-pumpen.de](mailto:anfrage@lutz-pumpen.de) | Phone +49 9342 879-260**





### Discover our online shop!

Register today and benefit from the advantages of logged-in customers.  
[www.lutz-pumpen.de/shop](http://www.lutz-pumpen.de/shop)

State of the art 05.2024 Order No. 0695-451

Sign up for the newsletter now and never miss any news again



Follow us on:



## Lutz Pumpen GmbH

Erlenstraße 5-7 | D-97877 Wertheim | Phone +49 9342 879-0 | [info@lutz-pumpen.de](mailto:info@lutz-pumpen.de) | [www.lutz-pumpen.de](http://www.lutz-pumpen.de)